

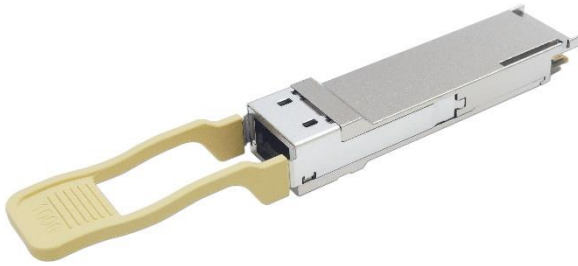

## **100G QSFP28 SR4 Dual-Rate Transceiver** **Hot Pluggable, MPO / MTP, 850nm VCSEL, MMF 100M, DDM**

**Part Number: FQ28-K9-M85-X1DR-OF1**



### **Overview**

FQ28-K9-M85-X1DR-OF1 is a parallel fiber optical transceiver module for 103/112Gbps data transmission applications at 850nm. It is ideally suited for datacom & storage area network (SAN/NAS) applications based on IEEE 802.3ba 100GBASE-SR4 & OTN OTU4 standard. Designed for short range multi-lane data communication, the QSFP28 full-duplex optical module with MPO-12 receptacle integrates four independent transmitter and receiver channels each capable 25.78/27.95Gbps operation for an aggregate data rate of 103/112Gbps up to MMF OM4 100m optical links.

### **Applications**

- 100GBASE-SR4 Ethernet @103.1G
- Breakout to 4 x 25GBASE-SR Ethernet
- OTN OTU4 @112.1G
- Data Centers Switch Interconnect
- Server and Storage Area Network Interconnect

### **Features**

- Compliant with IEEE802.3bm 100GBASE-SR4
- Compliant with ITU-T G.709 OTU4
- Compliant with SFF-8665 QSFP28 MSA
- Compliant with IEEE 802.3bm CAUI-4 Interface
- 4 independent full-duplex channels
- Dual-Rate 25.78125 / 27.9525Gbps per Lane
- Built in quad Tx CDR and Rx CDR
- Hot Pluggable QSFP28 footprint
- 4CH 850nm VCSEL array transmitter
- 4CH PIN array receiver
- MPO-12 receptacle connector
- 2-wire interface for management and diagnostic monitor compliant with SFF-8636
- Single 3.3V power supply
- Link distance 100m over OM4 fiber and 70m over MM OM3 fiber
- Maximum power consumption 3.5W
- RoHS compliant



## Laser Safety

- This is a Class 1 Laser Product complies with 21 CFR 1040.10 and 1040.11 except for conformance with IEC 60825-1 Ed. 3., as described in Laser Notice No. 56, dated May 8, 2019.
- Caution: Use of control or adjustments or performance of procedure other than those specified herein may result in hazardous radiation exposure.

## Absolute Maximum Ratings

Parameters	Symbol	Min.	Max.	Unit
Storage Temperature	T <sub>ST</sub>	-40	+85	°C
Storage Relative Humidity	RH	0	85	%
Supply Voltage	V <sub>CC3</sub>	-0.5	+3.6	V

## Recommended Operating Conditions

Parameters	Symbol	Min.	Typ.	Max.	Unit
Case Operating Temp. (FQ28-K9-M85-X1DR-OF1)	T <sub>OP</sub>	0	-	+70	°C
Case Operating Temp. (FQ28-K9-M85-X1DRi-OF1)	T <sub>OP</sub>	-40	-	+85	°C
Supply Voltage	V <sub>CC</sub>	+3.13	+3.3	+3.47	V
Data Rate, per Lane	DR		25.78125	27.9525	Gb/s
Data Rate Accuracy	ΔDR	-100		+100	ppm
Bit Error Rate	BER			5x10 <sup>-5</sup>	
Supply Current	I <sub>CC</sub>			1050	mA
Power Consumption	P			3.5	W
Transceiver Power-on Initialization Time				2000	ms
Control Input Voltage High	V <sub>IH</sub>	2.0		V <sub>CC</sub> +0.3	V
Control Input Voltage Low	V <sub>IL</sub>	GND		0.8	V
Control Output Voltage High	V <sub>OH</sub>	2.0		V <sub>CC</sub> +0.3	V
Control Output Voltage Low	V <sub>OL</sub>	GND		0.8	V



## Transmitter Electro-optical Characteristics

$V_{CC} = 3.13V$  to  $3.47V$ ,

$T_{OP} = 0\text{ }^{\circ}C$  to  $70\text{ }^{\circ}C$ (FQ28-K9-M85-X1DR-OF1);  $T_{OP} = -40\text{ }^{\circ}C$  to  $85\text{ }^{\circ}C$ (FQ28-K9-M85-X1DRi-OF1)

Parameters	Symbol	Min.	Typ.	Max.	Unit	Note
Operating Data Rate, per Lane	DR		25.78125	27.9525	Gb/s	
Average Launch Power, per Lane	$P_{AVG}$	-8.4		+2.4	dBm	
Optical Modulation Amplitude (OMA), per Lane	$P_{OMA}$	-6.4		+3	dBm	1
Difference in Launch Power between any two Lanes (OMA)	$P_{TX-DIFF}$			4	dB	
Transmitter Dispersion Penalty, per Lane	TDP			4.3	dBm	
Launch Power in OMA minus Transmitter and Dispersion Penalty, per Lane	OMA-TDP	-7.3			dB	1
Optical Wavelength, each Lane	$\lambda_c$	840	850	860	nm	1
Spectral Width (RMS)	$\Delta\lambda$			0.6	nm	
Optical Extinction Ratio	ER	3			dB	
Optical Eye Mask { X1, X2, X3, Y1, Y2, Y3 }		{ 0.28,0.34,0.43,0.36,0.44,0.4 }				2
Average Launch Power OFF, per Lane	$P_{OFF}$			-30	dBm	
Optical Return Loss Tolerance	ORLT			12	dB	
Input Differential Impedance	$Z_{IN}$	90	100	110	$\Omega$	
Differential Data Input Voltage	$V_{IN-PP}$	180		900	mVpp	

**Note1:** Transmitter wavelength, RMS spectral width and launch power need to meet the OMA minus TDP specs to guarantee link performance.

**Note2:** Hit ratio  $5 \times 10^{-5}$  hits per sample.



## Receiver Electro-optical Characteristics

$V_{CC} = 3.13V$  to  $3.47V$ ,

$T_{OP} = 0\text{ }^{\circ}C$  to  $70\text{ }^{\circ}C$ (FQ28-K9-M85-X1DR-OF1);  $T_{OP} = -40\text{ }^{\circ}C$  to  $85\text{ }^{\circ}C$ (FQ28-K9-M85-X1DRi-OF1)

Parameters	Symbol	Min.	Typ.	Max.	Unit	Note
Operating Data Rate, per Lane	DR		25.78125	27.9525	Gb/s	
Damage Threshold, per Lane	D <sub>TH</sub>	+3.4			dBm	1
Average Receive Power, per Lane	P <sub>RX-AVG</sub>	-10		+2.4	dBm	
Receive Sensitivity (OMA), per Lane	SEN <sub>OMA</sub>			-7.2	dBm	2
Optical Wavelength, each Lane	$\lambda_c$	840	850	860	nm	
Receiver Reflectance	R <sub>RX</sub>			-12	dB	
LOS De-Assert	LOS <sub>D</sub>			-10.5	dBm	
LOS Assert	LOS <sub>A</sub>	-30			dBm	
LOS Hysteresis	LOS <sub>HY</sub>	0.5			dB	
Output Differential Impedance	Z <sub>OUT</sub>	90	100	110	$\Omega$	
Differential Data Output Voltage	V <sub>OUT-PP</sub>	180		900	mVpp	

**Note1:** The receiver shall be able to tolerate, without damage, continuous exposure to a modulated optical input signal having this power level on one lane. The receiver does not have to operate correctly at this input power.

**Note2:** Measured with conformance test signal at receiver input for BER=  $5 \times 10^{-5}$ .

## Transceiver Block Diagram

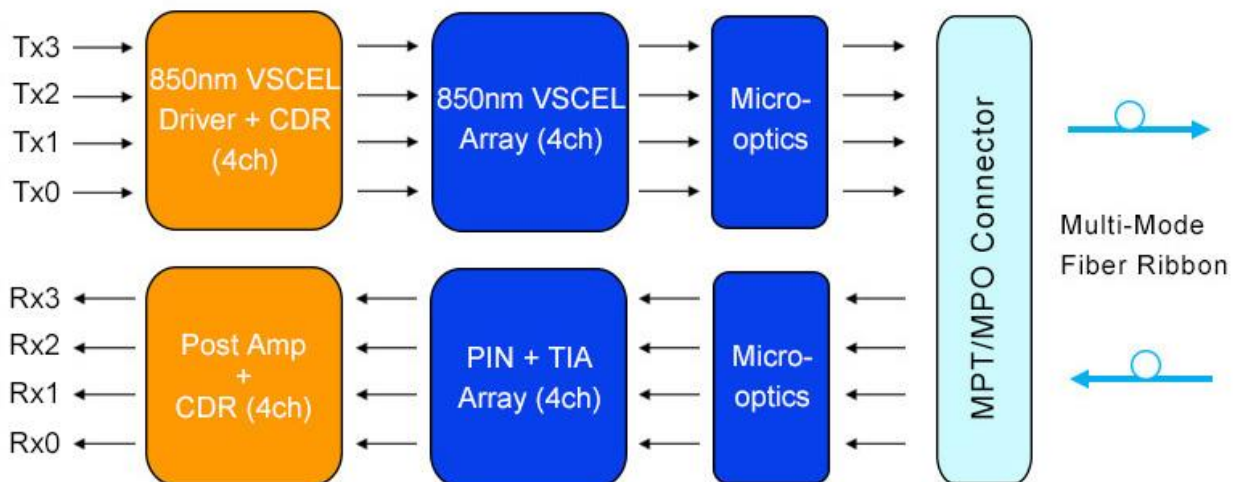



## Pin Assignment

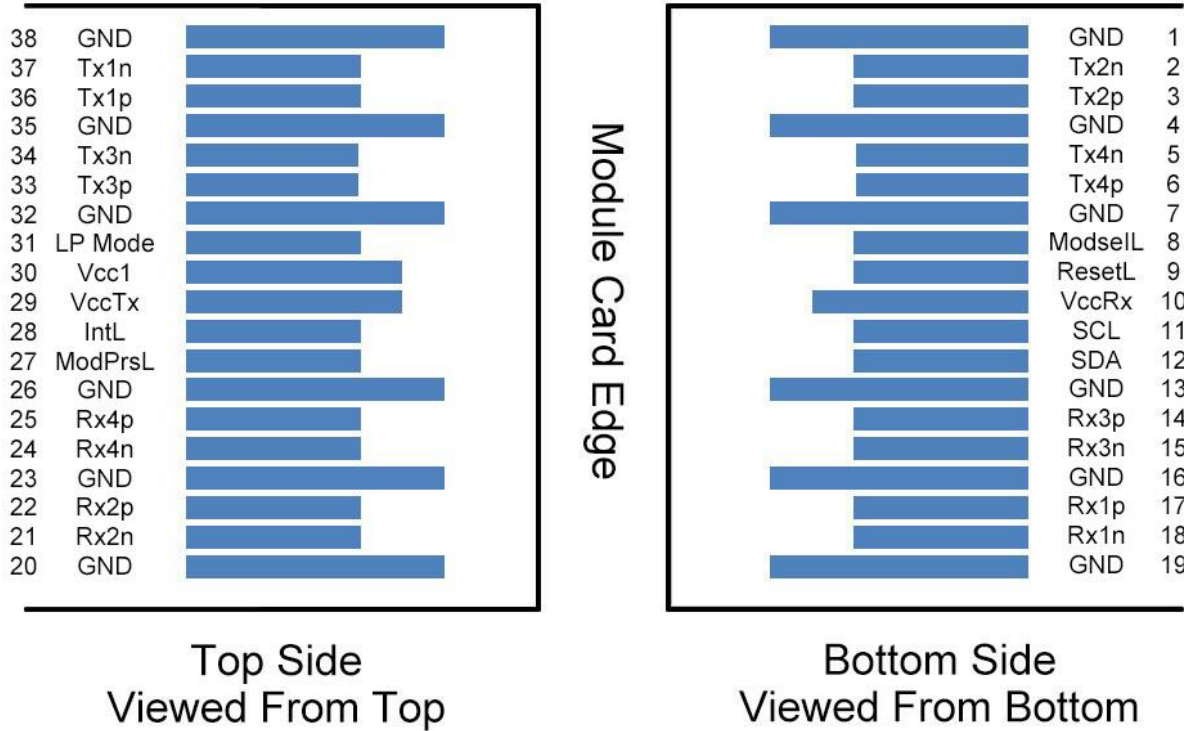

## Pin Description

Pin	Logic	Name	Function / Description
1		GND	Module Ground
2	CML-I	Tx2n	Transmitter Inverted Data Input
3	CML-I	Tx2p	Transmitter Non-Inverted Data Input
4		GND	Module Ground
5	CML-I	Tx4n	Transmitter Inverted Data Input
6	CML-I	Tx4p	Transmitter Non-Inverted Data Input
7		GND	Module Ground
8	LVTLL-I	ModSelL	Module Select
9	LVTLL-I	ResetL	Module Reset
10		VccRx	+3.3V Power Supply Receiver
11	LVC MOS-I/O	SCL	2-Wire Serial Interface Clock
12	LVC MOS-I/O	SDA	2-Wire Serial Interface Data



13		GND	Module Ground
14	CML-O	Rx3p	Receiver Non-Inverted Data Output
15	CML-O	Rx3n	Receiver Inverted Data Output
16		GND	Module Ground
17	CML-O	Rx1p	Receiver Non-Inverted Data Output
18	CML-O	Rx1n	Receiver Inverted Data Output
19		GND	Module Ground
20		GND	Module Ground
21	CML-O	Rx2n	Receiver Inverted Data Output
22	CML-O	Rx2p	Receiver Non-Inverted Data Output
23		GND	Module Ground
24	CML-O	Rx4n	Receiver Inverted Data Output
25	CML-O	Rx4p	Receiver Non-Inverted Data Output
26		GND	Module Ground
27	LVTLL-O	ModPrsL	Module Present
28	LVTLL-O	IntL	Interrupt
29		VccTx	+3.3V Power Supply Transmitter
30		Vcc1	+3.3V Power Supply
31	LVTLL-I	LPMODE	Low Power Mode
32		GND	Module Ground
33	CML-I	Tx3p	Transmitter Non-Inverted Data Input
34	CML-I	Tx3n	Transmitter Inverted Data Input
35		GND	Module Ground
36	CML-I	Tx1p	Transmitter Non-Inverted Data Input
37	CML-I	Tx1n	Transmitter Inverted Data Input
38		GND	Module Ground

**Note1:** GND is the symbol for signal and supply (power) common for QSFP28 modules. All are common within the QSFP28 module and all module voltages are referenced to this potential unless otherwise noted. Connect these directly to the host board signal common ground lane.

**Note2:** VccRx, Vcc1 and VccTx are the receiver and transmitter power suppliers and shall be applied concurrently. Recommended host board power supply filtering is shown below. Vcc Rx, Vcc1 and Vcc Tx may be internally connected within the QSFP28 transceiver module in any combination. The connector pins are each rated for a maximum current of 1000mA.



## Recommended Power Supply Filter

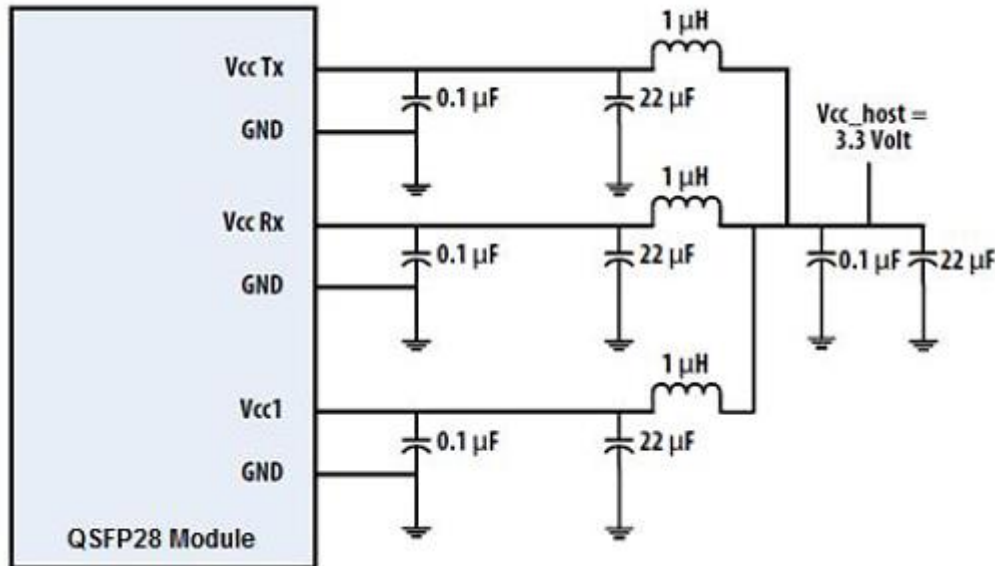

## Digital Diagnostic Functions

As defined by the QSFP28 MSA, Ficer's QSFP28 transceivers provide digital diagnostic functions via a 2-wire serial interface, which allows real-time access to the following operating parameters:

- Transceiver temperature
- Laser bias current (4-Channel)
- Transmitted optical power (4-Channel)
- Received optical power (4-Channel)
- Transceiver supply voltage

It also provides a sophisticated system of alarm and warning flags, which may be used to alert end-users when particular operating parameters are outside of a factory-set normal range.

The operating and diagnostics information is monitored and reported by a Digital Diagnostics Controller (DDC) inside the transceiver, which is accessed through the 2-wire serial interface. When the serial protocol is activated, the serial clock signal (SCL pin) is generated by the host. The positive edge clocks data into the QSFP28 transceiver into those segments of its memory map that are not write-protected. The negative edge clocks data from the QSFP28 transceiver. The serial data signal (SDA pin) is bi-directional for serial data transfer. The host uses SDA in conjunction with SCL to mark the start and end of serial protocol activation. The memories are organized as a series of 8-bit data words that can be addressed individually or sequentially. The 2-wire serial interface provides sequential or random access to the 8 bit parameters, addressed from 000h to the maximum address of the memory.

For more detailed information including memory map definitions, please see the QSFP28 MSA Specification.

## Digital Diagnostic Memory Map

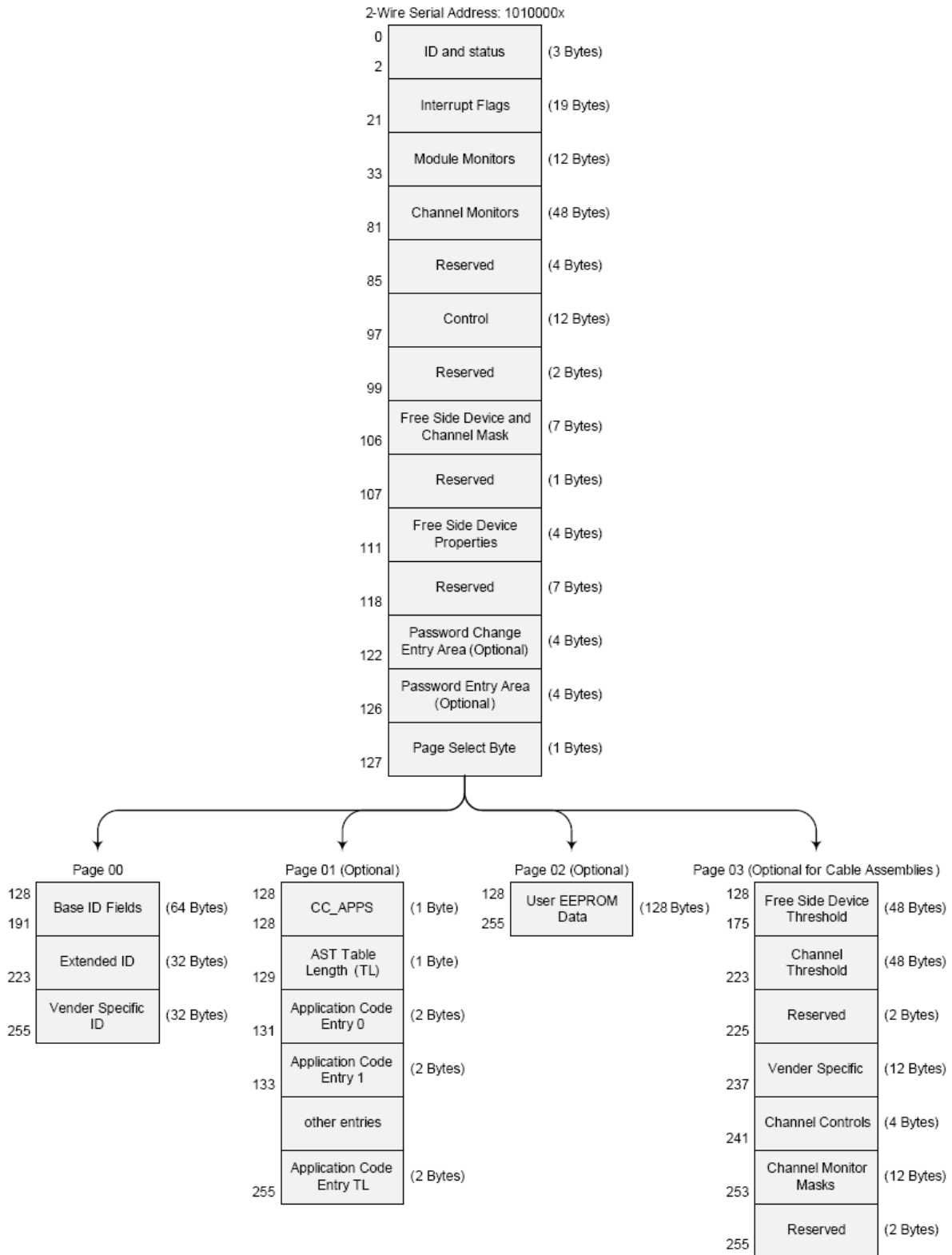





## Optical Interface Lanes and Assignment

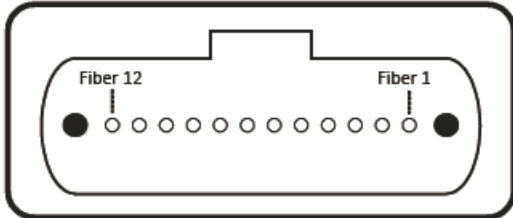

Outside View of the QSFP28 Module MPO

Fiber #	Lane Assignment
1	Rx0
2	Rx1
3	Rx2
4	Rx3
5,6,7,8	Not used
9	Tx3
10	Tx2
11	Tx1
12	Tx0

lane assignment



## Mechanical Dimensions

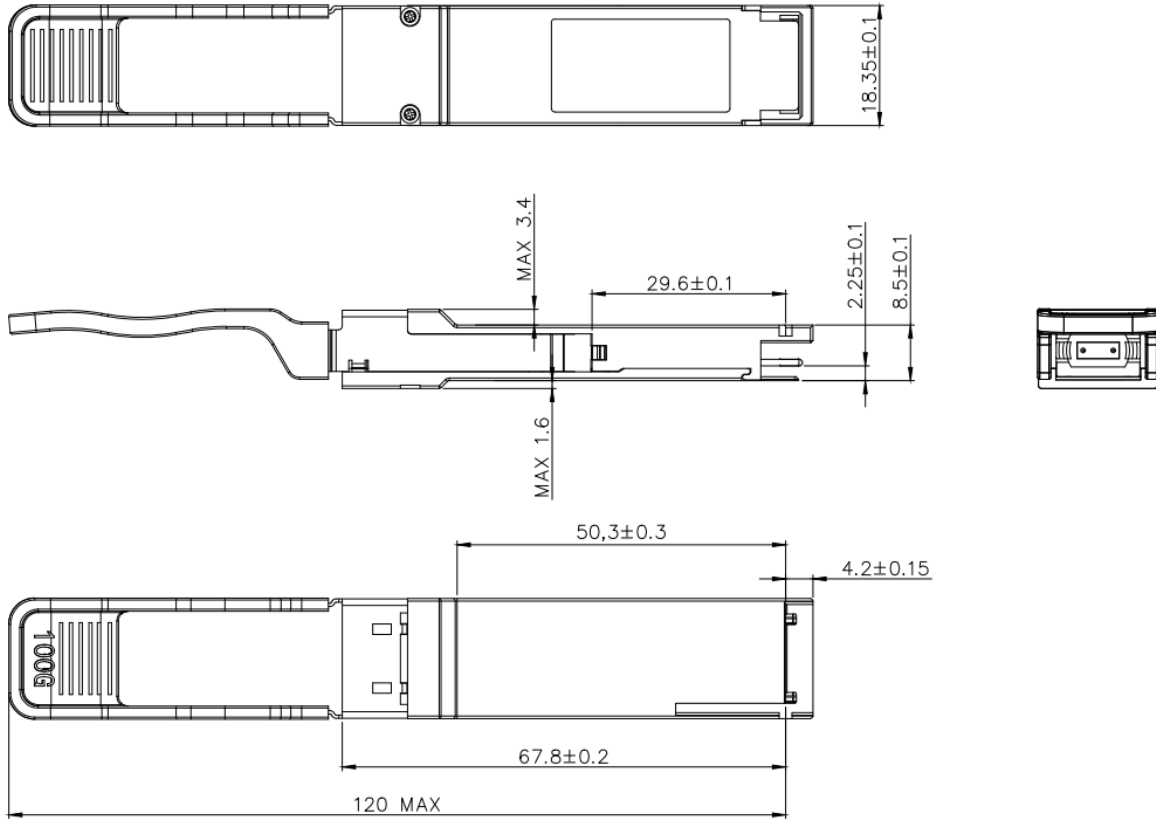

(All Dimensions are  $\pm 0.20$ mm Unless Otherwise Specified, Unit: mm)

## Ordering Information

Part No.	Tx	Rx	Link	DDM	Temp.
FQFP-K9-M85-X1DR-OF1	850nm	850nm	MM OM4: 100m MM OM3: 70m	Yes	0~70°C
FQFP-K9-M85-X1DRi-OF1					-40~85°C

**Note:** Distances are indicative only. To calculate a more precise link budget based on specific conditions in your application, please refer to the optical characteristics.